

BUG-1-3-0019

MEDICAL
CART COMPANY

Display and storage cart

-  **Ergonomic**
-  **Easy to clean**
-  **Multi purpose**
-  **Lifetime warranty**
-  **Quick setup**



FEATURES



Designed and manufactured in Hungary, products are typically 100% recyclable and upgradable in the future. Raw materials are sourced locally or in the EU.

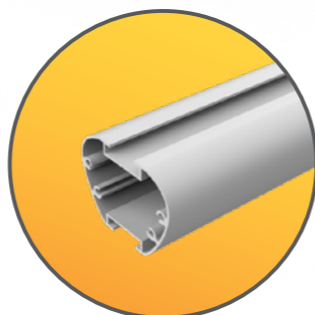

Channels to fix accessories



VESA Mount



Handle with hook

Cart Properties

Dimensions and mechanical data



More info on website

 Accessories available

 Display Mount Datasheet

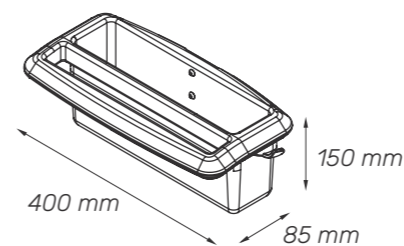

Storage with handle

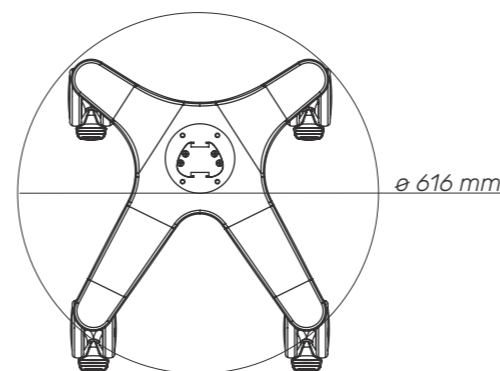

Base

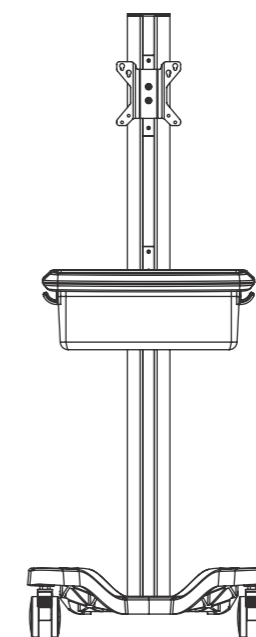

Front

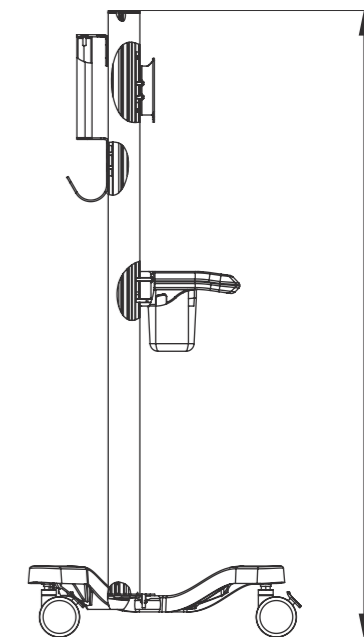

Side

Mechanical data

Height	1205 mm
Wheelbase dimension	616 mm (diameter)
Wheel construction	Polyamide with Polyurethane tread
Wheels/locking	2 lockable, 75 mm diameter
Loading capacity	25 kg
Display mount holes	75x75 mm, 100x100 mm

Construction

Main material	Aluminium
---------------	-----------

Color

RAL 9016	
Custom color	

Certificates

Certificates conforms to	IEC60601-1:2012 (Edition 3)
CE	Rohs compliant