

BUG-6-3-0146

MEDICAL
CART COMPANY

Cart with device holding plate and device fixing mount

-  Ergonomic
-  Easy to clean
-  Multi purpose
-  Lifetime warranty
-  Quick setup



FEATURES

Designed and manufactured in Hungary, products are typically 100% recyclable and upgradable in the future. Raw materials are sourced locally or in the EU.



Safe device mounting,
custom parts available

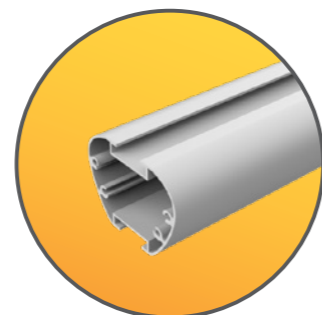

Channels to
fix accessories



Lockable wheels

Cart Properties

Dimensions and mechanical data



More info
on website

 Accessories
available

 Quick release mount
Datasheet

 Gas bottle holder
Datasheet

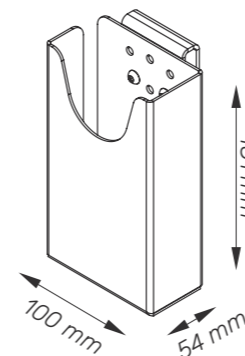

Holder

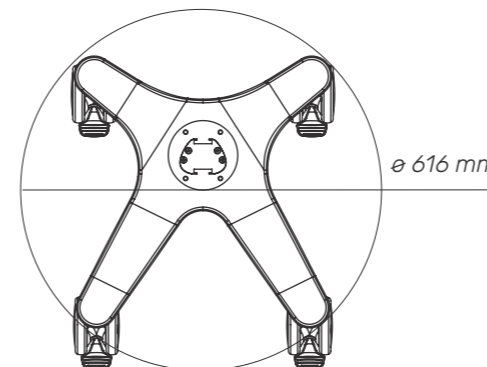

Base

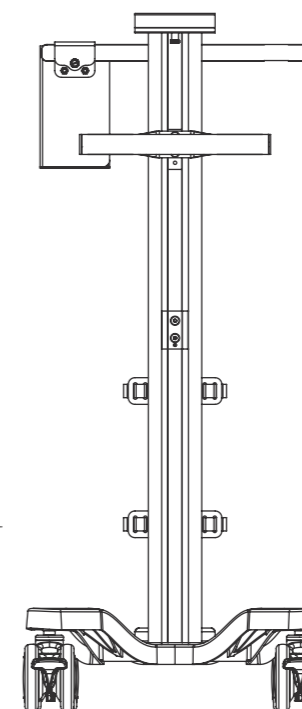

Front

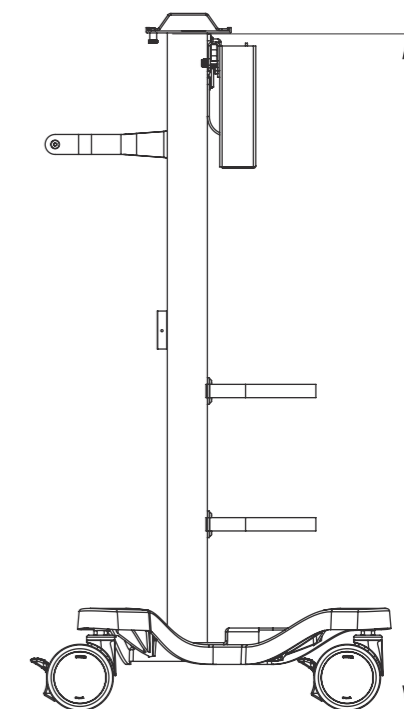

Side

Mechanical data

Height	996 mm
Wheelbase dimension	616 mm (diameter)
Wheel construction	Polyamide with Polyurethane coating
Wheels/locking	2 lockable, 100 mm diameter
Loading capacity	25 kg

Construction

Main material Aluminium

Color

RAL 9016

Custom color

Certificates

Certificates conforms to IEC60601-1:2012 (Edition 3)

CE

Rohs compliant